

WARDRAY PREMISE

MR1505 MR Conditional Fixed Height Cube Trolley



OPERATORS MANUAL





Introduction

Thank you for purchasing this MR Conditional product. Manufactured and tested to the highest standards it is guaranteed MR Conditional to 7.0T.

Our products are manufactured by Wardray Premise Ltd to BS EN ISO 13485:2016 and are CE marked.

Manufacturing address:

**Wardray Premise Limited, Northern Regional Office,
Unit 2, Springvale Works, Elland Road,
Brighouse, West Yorkshire, HD6 2RN, UK**



To ensure that you obtain maximum benefit from your product, please take a few minutes to read the enclosed information regarding operation, service and maintenance.

If you have any problems in the meantime or would like any advice about this or any other MR products from the Wardray Premise range, please contact us at our **Head Office**:

**Wardray Premise Limited, Hampton Court Estate, Summer Road
Thames Ditton, Surrey, KT7 0SP, UK**

**Tel: +44 (0) 20 8398 9911
Fax: +44 (0) 20 8398 8032**

E-mail: sales@wardray-premise.com

Kindly note:

If you modify a Wardray Premise product you will invalidate your warranty. Unless you have our express written permission to modify a product, we transfer all liabilities for modified products to you.

EU Authorised Representative:

Advena Ltd
Tower Business Centre
2nd Floor, Tower Street
Swatar
BKR 4013
Malta



Safety Definitions for MRI as Defined by International Standard F2503-13

MR SAFE:



An item that poses no known hazards resulting from exposure to any MR environment. MR SAFE items are composed of materials that are electrically non-conductive, non-metallic, and non-magnetic.

MR CONDITIONAL:



An item with demonstrated safety in the MR environment within defined conditions. At a minimum, address the conditions of the static magnetic field, the switched gradient magnetic field and the radiofrequency fields. Additional conditions, including specific configurations of the item, may be required.

Supplementary marking – additional information that, in association with marking as “MR CONDITIONAL,” states via additional language the conditions in which an item can be used safely within the MR environment.



MR UNSAFE:

An item which poses unacceptable risks to the patient, medical staff or other persons within the MR environment.



Specification

The MR1505 Cube Trolley is designed to be MR Conditional and is manufactured and tested to the highest standards.

The MR1505 is constructed from aluminium box section, which whilst being MR compatible is also lightweight, with solid grade plastic boards to support the pads, making the MR1505 very light and easily manoeuvrable.

A fold away step on either side of the trolley has been fitted to aide mounting and alighting the trolley.

It is advisable that the product is inspected and serviced every 12 months by a Wardray Premise trained engineer.

A service contract package is available, and details are available upon request from our Service Department on +44 (0) 20 8398 9911.

For international customers please contact your local Wardray Premise representative for assistance.

Table top size mm 1906 x 550	Max length mm 1906	Max width mm 688	Low height mm N/A	Top height mm 815	Max load Kg 223
---	-----------------------------------	---------------------------------	----------------------------------	----------------------------------	--------------------------------

Maximum patient weight 35 Stone / 223 Kg

Important Information

This MR Conditional Cube Trolley has been designed for adult patients. If you use the trolley to transport a child extra care should be taken particularly regarding the movement of the child across the mattress and the potential for their limbs or other body parts to protrude through the trolley sides, potentially causing injury / harm. Wardray Premise Ltd also offer a range of paediatric trolleys with cot bumpers for the safe transportation of children.

MR1505 Trolley parts reference

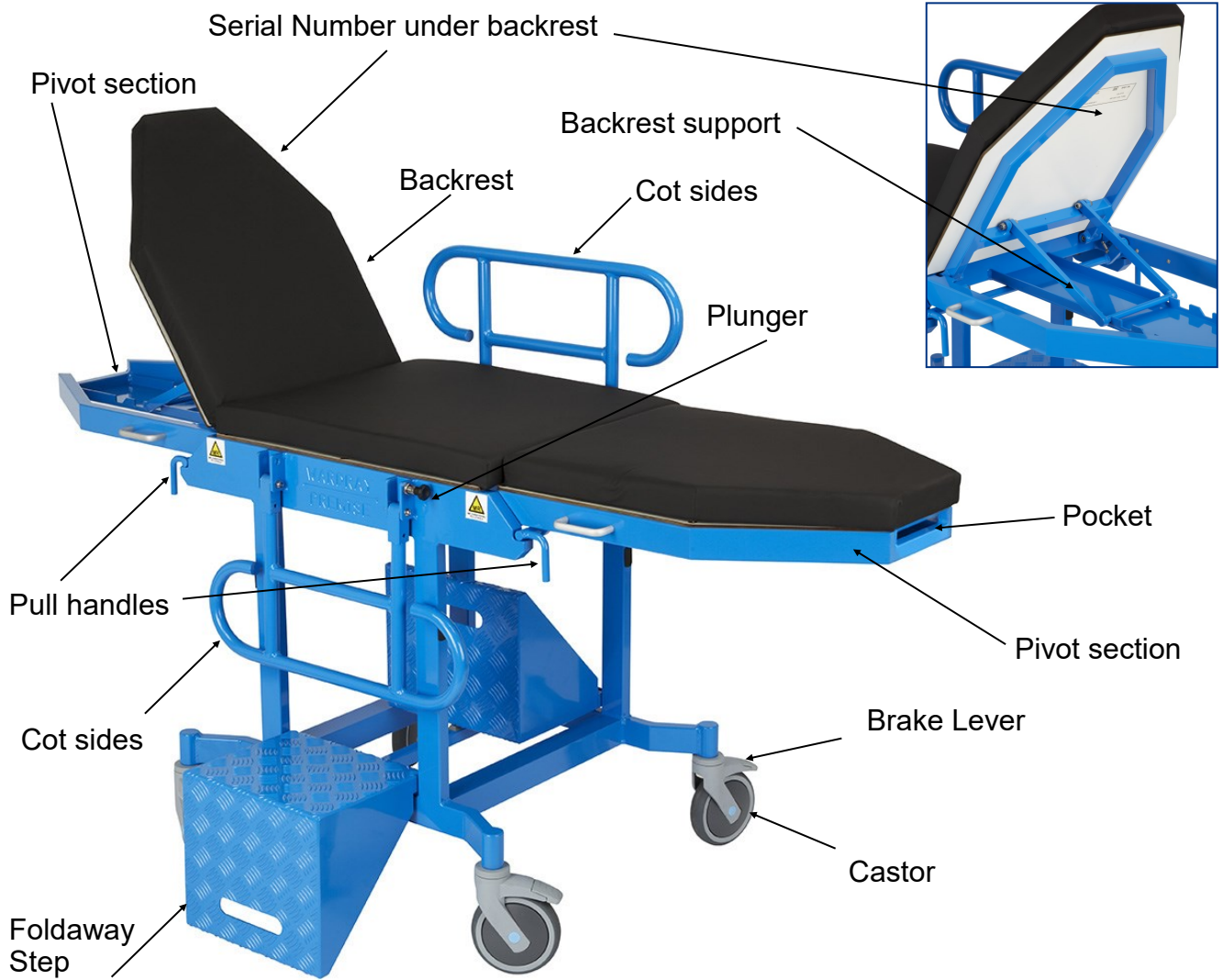

Trolley fully folded

Handle to raise / lower
Pivot section



WARDRAY PREMISE

Operating instructions

Pivot Sections



Fig1

When the trolley is not in use it folds away into a handy size; (L) 900 x (W) 688 x (H) 865mm, this is particularly convenient when space is at a premium.

The trolley has two pivot sections one on each end (Fig 1). The pivot sections can be raised from vertical to horizontal by simply grasping the handles on either side of the pivot section, and raising to slightly above horizontal, you will then hear the lock bar click into place.

Make this adjustment without the patient on the trolley.



Fig 2

To lower the pivot section, hold the raised end of the pivot section and raise slightly above horizontal, place your finger around the blue pull handle (Fig 2) and pull backwards, this will disengage the lock bar. Hold the pull handle until the lock bar is clear, release the pull handle and simply lower the pivot section until it rests on the base.

Make this adjustment without the patient on the trolley.

Operating instructions

Backrest

The trolley has adjustable raise and lower back and foot rests, enabling a Trendelenburg action.

The rests can be deployed by simply placing your hand into the pocket at the head or foot end section, and lifting, when the desired angle is achieved lower until the rest support arm has engaged into the slot, as shown (Fig 1).

To lower the backrest hold the backrest board from the underside and raise until the backrest support (Fig 2) can swing freely, pull the backrest support towards the rear of the trolley and lower the board.

When moving the backrest into its flat/horizontal position, ensure nothing can become trapped between the framework and the backrest

IMPORTANT NOTE: When adjusting the backrest position while a patient is on the trolley we strongly advise this is done by two members of staff, one to support the patient and one to adjust the backrest.



Fig 1



Fig 2

Operating Instructions

Cot Sides



Fig 1

The trolley is fitted with rotating cot sides (Fig 1) these protect the patient during transportation to and from the ward.

The cot sides should not be used to steer/push the trolley.

Depending on the design of the trolley, it will be fitted with one or other of the plungers indicated below; Standard Plunger (Fig 2) or Flag Plunger (Fig 4)

Standard Plunger



Standard Plunger engaged Fig 2

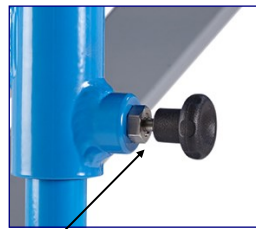

Standard Plunger disengaged Fig 3

To operate the Standard Plunger:

To lower the cot sides, pull the black plunger to disengage (Fig 3) and lift the cot side upwards, outwards and lower until the cot side is in a vertical position (Fig 1).

To raise the cot sides, disengage the plunger (Fig 3), hold the cot side in the centre and lift outwards and upwards and engage the plunger (Fig 2).

Flag Plunger



Flag Plunger engaged Fig 4



Flag Plunger disengaged Fig 5

To operate Flag Plunger:

To lower the cot sides, disengage the black 'flag' plunger (Fig 4) by pulling and turning upwards until it snaps into the notch vertically and pointing upward (Fig 5), lift the cot side upwards, outwards and lower until the cot side is in a vertical position (Fig 1).

To raise the cot sides, disengage the plunger (Fig 5). Pull and rotate the flag plunger until it snaps into the vertical downward position (Fig 4). Once partially turned the flag will snap into the notch at the bottom to be in the engaged position. Hold the cot side in the centre and lift outwards and upwards and engage the plunger.

IMPORTANT NOTE: Do not attempt to push the cot sides down while the plunger is still engaged.

Operating Instructions

Folding side steps

To aid in the mounting and alighting of the trolley it is fitted with fold-away steps (Fig 1). Ensuring the cot side is secured in it's upright position (Fig 2), the step is easily moved into or out of it's stowed position under the trolley. There is a step on either side of the trolley.

When using the step to mount / dismount the trolley the cot side should be in the lowered position (Fig 1).

Please ensure that both steps are in their stowed position under the trolley before moving the trolley / transporting the patient.

The maximum weight on the step must not exceed the weight loading of the trolley of 35 stone / 223Kg.



Fig 1

IMPORTANT NOTE: Ensure the trolley is on level ground and all brakes are applied before allowing a patient to mount or dismount the trolley.



Fig 2

Operating Instructions

Castors

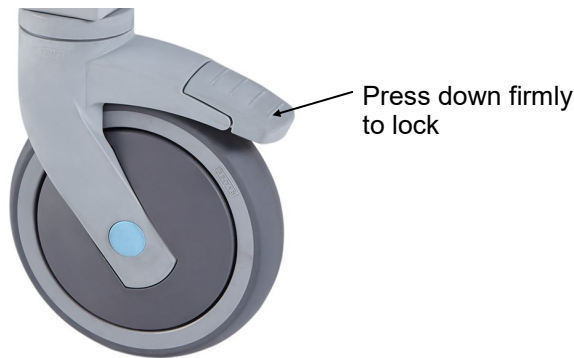

Fig 1

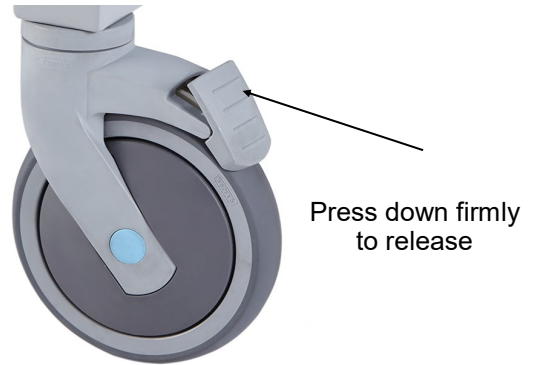

Fig 2

The trolley is fitted with four 150mm diameter, individually braked castors.

To engage the brakes, place your foot on the front part of the brake lever (Fig 1) and push down firmly, the brake will lock in place and stop the castor from moving.

To release the brake place your foot on the rear part of the brake lever (Fig 2) and press down firmly, this will release the brake.

The trolley has the option for a Directional Locking Castor denoted by the green locking lever.

- ① Standing at the head end of the trolley, push the trolley forward by approximately 1 metre. This will ensure that the directional locking castor is the 'trailing' position under the trolley (Fig 3).
- ② Engage the directional lock by pushing down firmly on the green lever (Fig 4).
- ③ To release the directional lock place your foot on the green lever, on the raised part, and press firmly to release (Fig 5).

Push forward from
head end

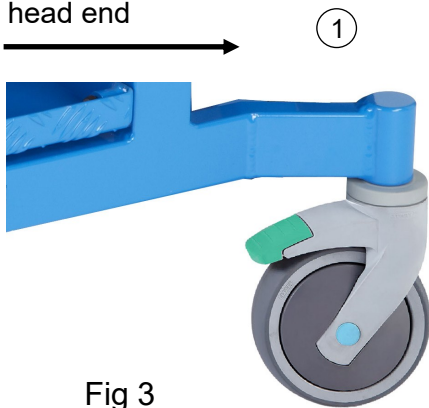

Fig 3



Fig 4



Fig 5

WARDRAY PREMISE

Operating Instructions

IV Pole

An IV Pole and holder can be ordered as an optional extra.

The IV Pole holder can be positioned on either of the pivot sections and on the right or left hand side.

Please note that there is no facility on the trolley for storing the IV Pole when not in use.

Ensure that the IV Pole has been removed prior to folding the trolley.

IMPORTANT NOTE: As a safety precaution, please check the serial No. of the IV Pole matches the trolley's serial No. before using.





Do's and Dont's

Do ensure the following are observed:

- The trolley should only be used by properly trained staff at all times.
- The trolley must be operated by 2 people when transporting a patient.
- When a patient is on board, the cot sides must be in an upright locked position before moving the trolley.
- The trolley must only be used for the purpose for which it was designed.

Don't:

- lift the trolley upwards by the top.
- push the trolley over rough or uneven ground.
- drop heavy or sharp objects onto the solid plastic table top.
- push the trolley by the cot sides, these are for patient safety only.
- place a weight of over the equivalent of 35 Stone (223Kg/490lbs) onto the trolley.
- place a weight of or equivalent to 7 Stone 12lbs (45Kg/99lbs) on either of the pivot sections.
- spill oil or other liquids/chemicals on the mattress.
- attempt to rectify any faults on the trolley without contacting Wardray Premise Ltd.
- use the trolley without a mattress.
- allow staff or patients to fix or store any items on the trolley unless you have verified the MR safety of the items.

The trolley should be serviced regularly, but only by Wardray Premise trained engineers, as they will carry the correct spares to guarantee safety and compatibility of the trolley. Failure to comply with this will invalidate your warranty and could compromise its MR compatibility and therefore safety.

Any serious incidents that occur in relation to this device should be reported to Wardray Premise LTD and the competent authority of the member state in which the user and/or patient are established.



General Maintenance

It is strongly recommended that the following checks are carried out on a weekly basis by trained personnel, to ensure trouble free operation of the trolley.

- Check the solid plastic table top for cracks or other obvious signs of damage or contamination. Report any damage found.
- Check mattress for any sign of damage or contamination. Report damage or clean where necessary with mild soap and water.
- Check castors for free movement and the braking mechanism for functionality, check and remove any debris that may have been caught between the forks and around the axles, This is a common occurrence and can lead to a shortened life expectancy of the castor if left unattended.
- Check the pivot sections for ease of movement and the lock bar mechanism.
- Check the backrest function, including the ability to lock into each of the positions.
- Check the cot sides for functionality and damage, especially the cot side brackets and plungers, as these take the brunt of any impacts from the side. Ensure that the plungers work freely and locate into the holes.
- Check the operation of the steps for free movement and stability.
- If an IV Pole is fitted ensure the serial no. corresponds with the trolley serial no. located on the inside of the backrest board (see page 5 for location). Make sure there are no sharp burrs from misuse.

Please register your product with us, via the Warranty Registration Form (see page 15), for ease of contact in case of urgent upgrades or recalls.

If the unit is damaged please do not attempt to repair as this could invalidate your warranty and could compromise its MR integrity and therefore safety, please call or email Wardray Premise Limited:

T: +44 (0) 20 8398 9911
F: +44 (0) 20 8398 8032
E-MAIL: sales@wardray-premise.com

Please include the product code and the product's serial number when contacting Wardray Premise.



Cleaning

This product should be washed with a disposable cloth wrung out in a solution of warm water and detergent. The product should be rinsed with warm water and dried thoroughly with paper towels.

If required the product can be washed down with hand hot sodium hypochlorite solution up to 1% or 10000 parts per million chlorine combined with a detergent. Alternatively, follow your local guidelines or instructions.

If any of the above give cause for concern, please contact your Wardray Premise service provider.

EU Declarations of Conformity and Magnetic Testing

Documentation is available upon request.



Wardray Premise Limited
Hampton Court Estate
Summer Road Thames Ditton
Surrey KT7 0SP
UK

Tel: +44 (0)20 8398 9911

Fax: +44 (0)20 8398 8032

e-mail: sales@wardray-premise.com

Website: www.wardray-premise.com

WARRANTY REGISTRATION FORM

To receive full warranty cover on your equipment, please complete and return this form at your earliest convenience

Reply e-mail: sales@wardray-premise.com

Reply Fax: +44 (0)20 8398 8032

Name:	
Job Title:	
Company:	
Address:	
Telephone:	
Fax:	
Email:	
Product Code/ Description:	
Product Serial/ Reference No:	
Please enter date Product received:	

If your department currently has any other Wardray Premise Ltd. equipment, which is not already covered under a service contract, please contact Servicing-Admin@wardray-premise.com to discuss an all-inclusive package.

If you would like any further information or would like to be contacted regarding any of our products, please add your enquiry to the box below.